

22.0 – 23.0 GHz Coaxial Isolators, K-band, 2A9NKC-ROHS and 2A9NKE-ROHS
25.5 – 27.0 GHz Coaxial Isolators, K-band, 2A9NKD-ROHS and 2A9NKF-ROHS
31.8 – 32.3 GHz Coaxial Isolators, Ka-band, 2A9NKA-ROHS and 2A9NKB-ROHS

Available in multiple frequency ranges, REC has the K and Ka band coaxial isolators to fit your needs. Ideal for satellite communication applications and terrestrial VSAT, they offer a small footprint with high isolation and low insertion loss.



Features and Benefits

- Ideal for satellite communication systems
- Low insertion loss
- K and Ka-band adaptable

Specifications

Frequency	22.0 – 23.0 GHz 25.5 – 27.0 GHz 31.8 – 32.3 GHz
Insertion Loss	0.6 dB
Isolation	20 dB
VSWR	1.25:1
Power	1 Watt
Temperature	-10°C to 70°C
Size	.83" x .50" x .50"

2A9NKC-ROHS and 2A9NKE-ROHS

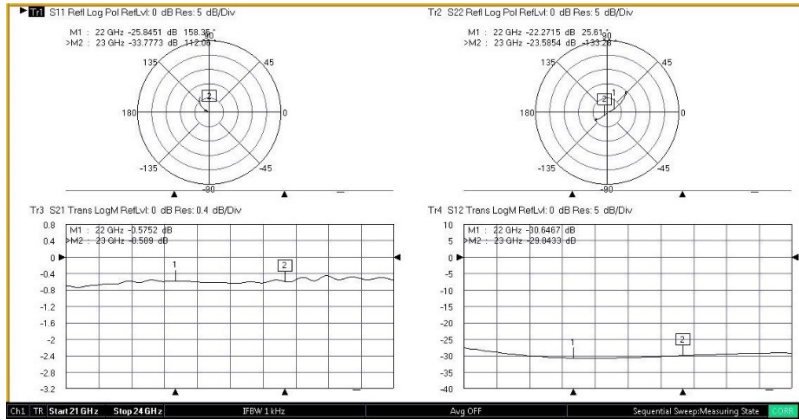

2A9NKD-ROHS and 2A9NKF-ROHS

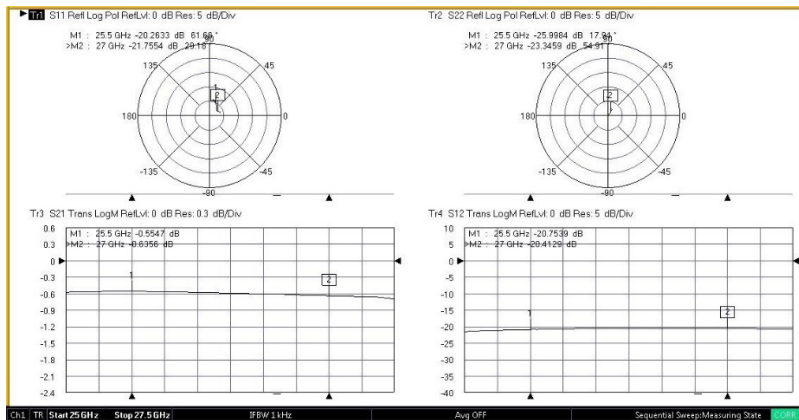

2A9NKA-ROHS and 2A9NKB-ROHS

